

Grade 7

**CONTENT BOOKLET:
TARGETED SUPPORT
MATHEMATICS**

Term 2

A MESSAGE FROM THE NECT

NATIONAL EDUCATION COLLABORATION TRUST (NECT)

Dear Teachers

This learning programme and training is provided by the National Education Collaboration Trust (NECT) on behalf of the Department of Basic Education (DBE)! We hope that this programme provides you with additional skills, methodologies and content knowledge that you can use to teach your learners more effectively.

What is NECT?

In 2012 our government launched the National Development Plan (NDP) as a way to eliminate poverty and reduce inequality by the year 2030. Improving education is an important goal in the NDP which states that 90% of learners will pass Maths, Science and languages with at least 50% by 2030. This is a very ambitious goal for the DBE to achieve on its own, so the NECT was established in 2015 to assist in improving education.

The NECT has successfully brought together groups of people interested in education so that we can work collaboratively to improve education. These groups include the teacher unions, businesses, religious groups, trusts, foundations and NGOs.

What are the Learning programmes?

One of the programmes that the NECT implements on behalf of the DBE is the 'District Development Programme'. This programme works directly with district officials, principals, teachers, parents and learners; you are all part of this programme!

The programme began in 2015 with a small group of schools called the Fresh Start Schools (FSS). The FSS helped the DBE trial the NECT Maths, Science and language learning programmes so that they could be improved and used by many more teachers. NECT has already begun this scale-up process in its Provincialisation Programme. The FSS teachers remain part of the programme, and we encourage them to mentor and share their experience with other teachers.

Teachers with more experience using the learning programmes will deepen their knowledge and understanding, while some teachers will be experiencing the learning programmes for the first time.

Let's work together constructively in the spirit of collaboration so that we can help South Africa eliminate poverty and improve education!

CONTENTS

INTRODUCTION:	vi
TOPIC 1: COMMON FRACTIONS	13
TOPIC 2: DECIMAL FRACTIONS	26
TOPIC 3: FUNCTIONS AND RELATIONSHIPS	34
TOPIC 4: AREA AND PERIMETER OF 2D SHAPES	39
TOPIC 5: SURFACE AREA AND VOLUME OF 3D OBJECTS	48

TOPIC 1: COMMON FRACTIONS

INTRODUCTION

- This unit runs for 9 hours.
- This unit falls under the Outcome, Numbers, Operations and Relationships.
- This outcome counts for 30% of the final exam.
- This unit covers concepts and skills for a variety of calculations using common fractions and leads to a clear understanding required for factorising and algebraic fractions in Grade 9 and the FET phase.
- It is important for the learners to be able to understand and apply the concepts dealt with in this unit. A number of concepts are applied, such as: equivalence, lowest common denominator (LCD) and comparing and ordering of fractions.
- Learners are introduced to new concepts such as: finding the lowest common denominator (LCD), percentages and the multiplication of common fractions.
- Remember it is important to reinforce mental calculations across the four basic operations wherever possible, throughout each section of the topic.

SEQUENTIAL TEACHING TABLE

INTERMEDIATE PHASE/ GRADE 6	GRADE 7	GRADE 8 SENIOR PHASE/ FET PHASE
LOOKING BACK	CURRENT	LOOKING FORWARD
<ul style="list-style-type: none"> • Compare and order common fractions, including tenths and hundredths • Addition and subtraction of common fractions in which one denominator is a multiple of another • Addition and subtraction of mixed numbers • Fractions of whole numbers • Solve problems in contexts involving common fractions, including grouping and sharing • Find percentages of whole numbers • Recognize and use equivalent forms of common fractions with 1-digit or 2-digit denominators [fractions in which one denominator is a multiple of another] • Recognize equivalence between common fraction and decimal fraction forms of the same number • Recognize equivalence between common fractions, decimal fractions and percentage forms of the same number 	<ul style="list-style-type: none"> • Compare and order common fractions with different denominators [halves; thirds; quarters; fifths; sixths; sevenths; eighths] • Describe and compare common fractions in diagram form • Addition of common fractions with the same denominators • Recognize, describe and use the equivalence of division and fractions • Solve problems in contexts involving fractions, including grouping and equal sharing • Recognize and use equivalent forms of common fractions [fractions in which one denominator is a multiple of another] 	<ul style="list-style-type: none"> • Compare and order common fractions, including tenths and hundredths • Addition and subtraction of common fractions in which one denominator is a multiple of another • Addition and subtraction of mixed numbers • Fractions of whole numbers • Solve problems in contexts involving common fractions, including grouping and sharing • Find percentages of whole numbers • Recognize and use equivalent forms of common fractions with 1-digit or 2-digit denominators [fractions in which one denominator is a multiple of another] • Recognize equivalence between common fraction and decimal fraction forms of the same number • Recognize equivalence between common fraction, decimal fraction and percentage forms of the same number • Extend all the skills to an algebraic context in the senior and FET phase.

GLOSSARY OF TERMS

Term	Explanation / Diagram
Numerator	This is the number at the top of a fraction.
Denominator	This is the number at the bottom of the fraction.
Proper Fractions	A fraction that has a numerator that is smaller than the denominator.
Improper Fractions	A fraction that has a numerator that is larger than the denominator.
Mixed Numbers	These fractions represent complete wholes, as well as excess parts of a further whole.
Equivalent Fractions	These are fractions that represent equivalent parts of a whole when compared to each other.
Lowest Common Denominator (LCD)	This is the denominator that actually represents the lowest common multiple that can be found by comparing the various denominators in the calculation.
Percentage	A percentage is a part of a whole represented as 100 parts.

SUMMARY OF KEY CONCEPTS

Fractions:

Revision of Grade 6 concepts must be done to ensure that learners have a good understanding of all the basic concepts before new concepts are taught. This is also the best time to revise the rules relating to the simplification of fractions, as this will be very important later on in this section.

Simplification of fractions involves writing the fraction in its simplest form and makes use of all the division rules and skills learners have been previously taught in Grade 6, and earlier in Grade 7.



EXAMPLE:

$$\frac{10}{15} = \frac{(10 \div 5)}{(15 \div 5)} = \frac{2}{3}$$

This fraction is in its simplest form, as the numerator and the denominator cannot be made any smaller.

It is very important that enough revision is done so that learners can identify improper and mixed number fractions.



Teaching Tip: Various simple tools can make this section less boring, and can encourage learners to engage with the topic. Resources such as a wall chart or number line can be used in this section. The more examples you give your learners, the better. Try to make use of some real examples, and not just the ones in a textbook. Make very sure that your learners know where the numerator is and where the denominator is in a fraction, as many learners cannot identify where these are, leading to errors when calculating with fractions.

$$\frac{\text{numerator}}{\text{denominator}}$$

A fraction is made up of two parts: $\frac{\text{numbering part}}{\text{naming part}}$ called the $\frac{\text{numerator}}{\text{denominator}}$

Topic 1 Common Fractions

Equivalent Fractions

Learners must be able to recognise and determine equivalent fractions. Simplification of fractions is a really important part of understanding the equivalence of fractions.

Equivalent fractions are fractions that equal each other.

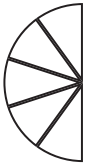
$\frac{1}{2}$  $\frac{5}{10}$ 

To change $\frac{1}{2}$ to $\frac{5}{10}$ we multiply the numerator and the denominator each by 5 like this:

$$\frac{1 \times 5}{2 \times 5} = \frac{5}{10}$$

The value of $\frac{5}{5}$ is 1 so we are not changing the value of the fraction, only its appearance

Examples of equivalent fractions:

$$\frac{12}{18} = \frac{6}{9} = \frac{2}{3}$$

$$\frac{2}{5} = \frac{4}{10} = \frac{6}{15}$$

Learners must be shown that the numerator and the denominator should always be multiplied or divided by the same amount, as this is the only way to obtain equivalent fractions.



EXAMPLE:

$$\frac{10}{15} = \frac{(10 \times 4)}{(15 \times 4)} = \frac{40}{60}$$



Teaching Tip: This section can be demonstrated very easily by using blank paper and folding it to represent various parts. This is a simple method that shows the same piece of paper “broken into” a varying number of parts. Using tangible apparatus to demonstrate this to learners is important as it gives a fixed idea of the concept.



Equivalent forms of fractions must be discussed, and learners must be able to look at a common fraction, decimal fraction and percentage that relates to the same number, and see that they are equivalent. (RESOURCE 2 AT THE END OF THIS SECTION)

Compare and order Fractions

A simple task of being able to order fractions either separated in a set, or on a number line, requires many basic skills brought together and introduces the concept of lowest common denominator (LCD).



1. Compare and order fractions as part of a set

Example:

Write the following in ascending order:

$$\frac{1}{2}, \frac{1}{3}, \frac{1}{6}, \frac{2}{3}, \frac{3}{4}$$

Use the lowest common denominator (LCD) and equivalent fractions, making each fraction have the same denominators. This way, they can be easily compared.

12 is the LCD in this case. Therefore, we need to change each of the fractions given to denominators of 12.

Now arrange these fractions in ascending order. The focus will now be on the numerators to find which fractions to use.

$$\frac{2}{12}, \frac{4}{12}, \frac{6}{12}, \frac{8}{12}, \frac{9}{12}$$

But when finalising the answer, fractions need to be written in the form they were originally given.

$$\frac{1}{6}, \frac{1}{3}, \frac{1}{2}, \frac{2}{3}, \frac{3}{4}$$

Topic 1 Common Fractions

2. Compare and order fractions on a number line.

The same process is followed, but learners must then place the fraction in the correct position on the number line.

Being able to draw number lines split up into different size fractions as shown below will be a useful skill in order to answer this type of question.

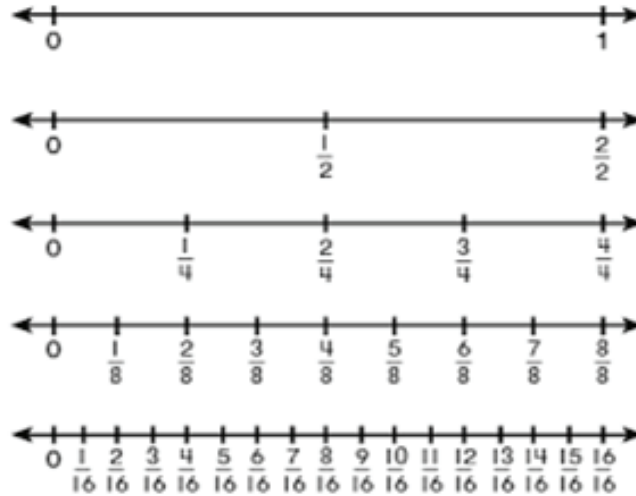

3. Comparing fractions in various forms.

Learners must know how to compare fractions in various forms. Comparisons made with proper, improper and mixed fractions in the set will ensure that the concept is completely understood

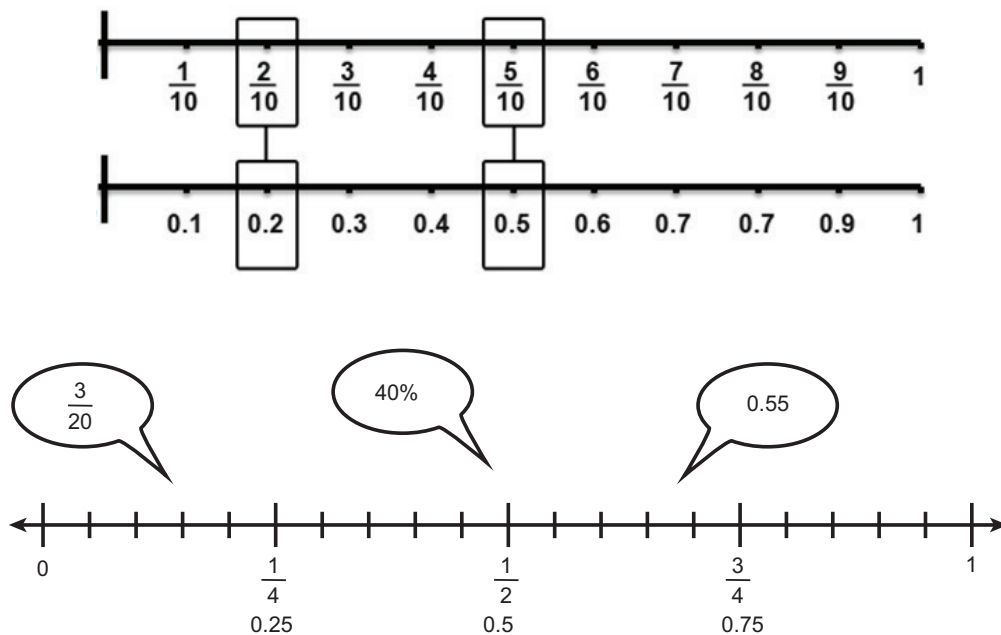

4. Learners must be able to compare fractions using $<$, $>$ and $=$ in their comparison.



Teaching Tip: Using examples where the value of items are represented as fractions can help give some realistic examples that will help learners to understand. Sales are an excellent real – life concept that will be useful in this section of work. Example: James wants to buy a new pair of basketball shoes. Two shops stock the shoes, and he is very lucky because both shops are having sales on the shoes he wants. The original price of the shoes is

R500. One shop offers a saving of $\frac{2}{3}$ off the price, the other offers a saving of $\frac{7}{12}$ off the price. Which store offers the best saving? As both shops offer the shoes at the same price, learners can compare the fractions and determine which fraction is greater. This is also a good opportunity to have learners check that their answer is sensible and is correctly calculated. Savings cannot be more than the original price.

Addition and Subtraction of Common Fractions

1. When adding or subtracting fractions, the lowest common denominator (LCD) must be found. It is easy to add or subtract fractions that have the same denominator, as this gives us parts of the whole that are the same size to work with.

Fractions with the same denominator:

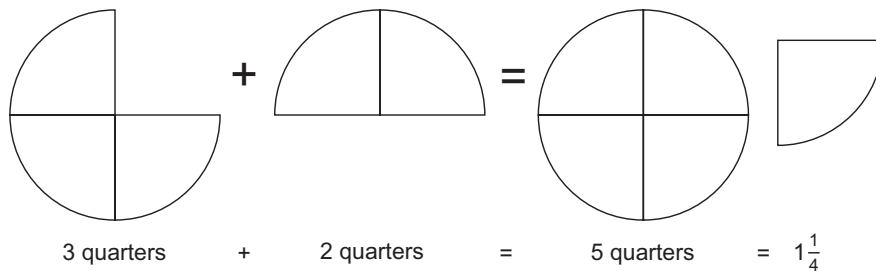

Fractions with different denominators. Note how the equivalent fractions need to be used in order to work with the same denominator.

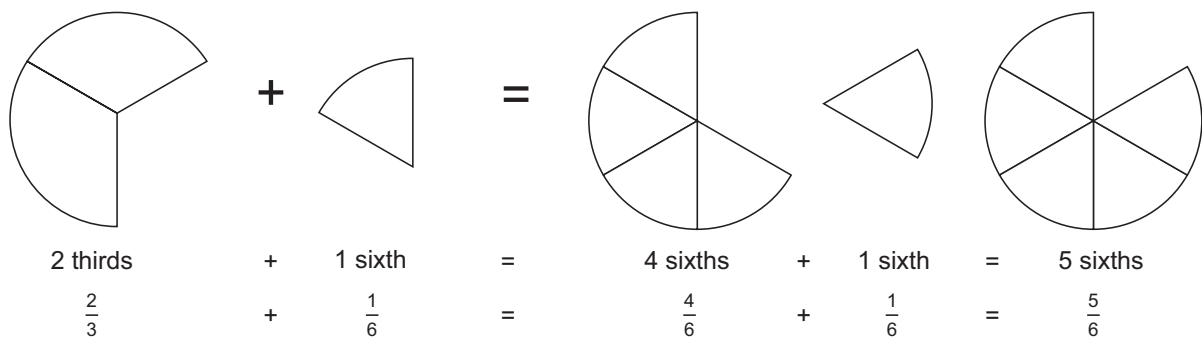

Topic 1 Common Fractions

2. Mixed numbers need to be changed into improper fractions before finding the LCD.



Example:

$$\begin{aligned} \text{a. } & 1\frac{1}{2} + \frac{2}{3} \\ & = \frac{3}{2} + \frac{2}{3} \\ & = \frac{9}{6} + \frac{4}{6} \\ & = \frac{13}{6} \\ & = 2\frac{1}{6} \end{aligned}$$



Teaching Tip: Learners at this stage often add or subtract fractions without first finding the LCD. This is incorrect and will cause confusion later when learners are introduced to algebra, where only like terms can be added or subtracted.

$$\begin{aligned} \text{b. } & 2\frac{2}{5} - 1\frac{3}{4} \\ & = \frac{12}{5} - \frac{7}{4} \\ & = \frac{48}{20} - \frac{35}{20} \\ & = \frac{13}{20} \end{aligned}$$



Note: At this stage of concept development, learners are expected to change improper fractions into mixed fractions.

Multiplication and Division of Common Fractions.

1. No LCD is required to multiply or divide.
2. Numerators get multiplied with numerators and denominators get multiplied with denominators.
3. It is best to simplify first before multiplying. This requires checking if any numerator in the question has a common factor with any denominator in the question.
4. If this step does not happen and multiplying begins immediately, the numbers to work with will be larger and the answer will need to be simplified at the end.
5. For division, the divide sign must be changed into a multiplication sign, then the fraction immediately after the change must be reciprocated (turned upside down).
6. Any mixed numbers must be turned into improper fractions.



Note - It is not advisable to just teach learners to 'tip and times' or 'change to multiply and reciprocate' when teaching division of fractions. This does not assist in their conceptual understanding. There is an explanation of why this works at the end of this topic. As the teacher, you should be aware of why it is possible to simply change to multiplication and reciprocate and even share it with your learners.

Examples:

$$\begin{aligned} \text{a. } & \frac{2}{5} \times \frac{15}{8} \\ & = \frac{1}{1} \times \frac{3}{4} \\ & = \frac{3}{4} \end{aligned}$$

Note: 2 and 8 have a Highest Common Factor (HCF) of 2, so this can be divided into both. Similarly, 5 and 15 have a HCF of 5.

$$\begin{aligned} \text{b. } & \frac{4}{7} \div \frac{12}{21} \\ & = \frac{4}{7} \times \frac{21}{12} \\ & = \frac{1}{1} \times \frac{3}{3} \\ & = \frac{1}{1} \times \frac{1}{1} = 1 \end{aligned}$$

Note: more simplifying can occur at this stage.

Topic 1 Common Fractions



$$\begin{aligned} \text{c. } & 3\frac{3}{4} \div \frac{9}{10} \\ & = \frac{15}{4} \times \frac{10}{9} \\ & = \frac{5}{2} \times \frac{5}{3} \\ & = \frac{25}{6} \\ & = 4\frac{1}{6} \end{aligned}$$

Note: HCF of 9 and 15 is 3. HCF of 4 and 10 is 2.



Teaching Tip: When multiplying by a whole number, learners often multiply both the numerator and the denominator by the whole number. It is a good idea to let learners change a whole number to a fraction, where the denominator is 1, as this will prevent errors from occurring.

Fractions as a Percentage

1. It is important to remember that a percentage is actually a fraction out of 100. A percentage of a number is a calculation where the number is multiplied by the percentage, as a fraction of 100.



EXAMPLE:

What is 32 % of R250?

32% of R250

$$\begin{aligned} & = \frac{32}{100} \text{ of } R250 \\ & = \frac{32}{100} \times \frac{250}{1} \\ & = \frac{16}{1} \times \frac{5}{1} \\ & = 80 \qquad \therefore R80 \text{ is } 32\% \text{ of } R250 \end{aligned}$$

2. If a common fraction is being changed to a percentage, the denominator needs to be changed to 100.

**EXAMPLE:**

Write $\frac{27}{30}$ as a percentage.

$$\begin{aligned} & \frac{27}{30} \times \frac{100}{1} \\ &= \frac{9}{10} \times \frac{100}{1} \\ &= \frac{9}{1} \times \frac{10}{1} \\ &= 90\% \end{aligned}$$

3. Calculation of percentage increase or decrease is a simple calculation.

$$\frac{(\text{Highest price} - \text{Lowest price})}{(\text{Original Price})} \times 100 \cdot$$

Point out to learners that the denominator is ALWAYS the original price.

**EXAMPLE:**

At the beginning of 2015, bread cost R 10, 00 per loaf. 1 year later, the same loaf of bread cost R 12, 00. By what percentage did the price of bread increase?

$$\begin{aligned} &= \frac{2}{10} \times \frac{100}{1} \\ &= \frac{2}{1} \times \frac{10}{1} \\ &= 20\% \end{aligned}$$

Topic 1 Common Fractions

RESOURCES



RESOURCE 1

1 whole											
$\frac{1}{2}$						$\frac{1}{2}$					
$\frac{1}{4}$			$\frac{1}{4}$			$\frac{1}{4}$			$\frac{1}{4}$		
$\frac{1}{6}$		$\frac{1}{6}$		$\frac{1}{6}$		$\frac{1}{6}$		$\frac{1}{6}$		$\frac{1}{6}$	
$\frac{1}{12}$	$\frac{1}{12}$	$\frac{1}{12}$	$\frac{1}{12}$	$\frac{1}{12}$	$\frac{1}{12}$	$\frac{1}{12}$	$\frac{1}{12}$	$\frac{1}{12}$	$\frac{1}{12}$	$\frac{1}{12}$	$\frac{1}{12}$

1 whole															
$\frac{1}{2}$								$\frac{1}{2}$							
$\frac{1}{4}$				$\frac{1}{4}$				$\frac{1}{4}$				$\frac{1}{4}$			
$\frac{1}{8}$		$\frac{1}{8}$		$\frac{1}{8}$		$\frac{1}{8}$		$\frac{1}{8}$		$\frac{1}{8}$		$\frac{1}{8}$		$\frac{1}{8}$	
$\frac{1}{16}$	$\frac{1}{16}$	$\frac{1}{16}$	$\frac{1}{16}$	$\frac{1}{16}$	$\frac{1}{16}$	$\frac{1}{16}$	$\frac{1}{16}$	$\frac{1}{16}$	$\frac{1}{16}$	$\frac{1}{16}$	$\frac{1}{16}$	$\frac{1}{16}$	$\frac{1}{16}$	$\frac{1}{16}$	$\frac{1}{16}$

1 whole									
$\frac{1}{2}$					$\frac{1}{2}$				
$\frac{1}{10}$	$\frac{1}{10}$	$\frac{1}{10}$	$\frac{1}{10}$	$\frac{1}{10}$	$\frac{1}{10}$	$\frac{1}{10}$	$\frac{1}{10}$	$\frac{1}{10}$	$\frac{1}{10}$
$\frac{1}{5}$		$\frac{1}{5}$		$\frac{1}{5}$		$\frac{1}{5}$		$\frac{1}{5}$	

1 whole								
$\frac{1}{3}$			$\frac{1}{3}$			$\frac{1}{3}$		
$\frac{1}{9}$	$\frac{1}{9}$	$\frac{1}{9}$	$\frac{1}{9}$	$\frac{1}{9}$	$\frac{1}{9}$	$\frac{1}{9}$	$\frac{1}{9}$	$\frac{1}{9}$

RESOURCES

COMMON FRACTION	DECIMAL FRACTION	PERCENTAGE
$\frac{1}{2}$	0.5	50%
$\frac{1}{3}$	0.333333...	33.3333...%
$\frac{1}{5}$	0.2	20%
$\frac{5}{8}$	0.625	62.5%
$\frac{3}{5}$	0.6	60%
$\frac{2}{3}$	0.666666...	66.6666...%
$\frac{1}{8}$	0.125	12.5%

RESOURCES

WHY DO WE 'TIP AND TIMES' TO DIVIDE FRACTIONS?

When multiplying fractions, we multiply numerators with numerators and denominators with denominators.

When dividing, it would seem intuitive to do the same – divide numerators with numerators and denominators with denominators. And we can!

This demonstration shows us why 'invert and multiply' or 'tip and times' really works:

Example:

$$\begin{aligned}\frac{2}{5} \div \frac{3}{4} \\ \frac{2}{5} \div \frac{3}{4} &= \frac{2 \div 3}{5 \div 4} \\ &= \frac{\frac{2}{3}}{\frac{5}{4}}\end{aligned}$$

This is the part where some knowledge of equivalent fractions is required. Fractions on top of fractions (compound fractions) can look messy. We need to sort that out. If we multiply the numerator and denominator by 3 (the denominator in the fraction at the top), the fraction will not change (since $3/3=1$ and multiplying by 1 does not change the number being multiplied).

Let's try that:

$$\begin{aligned}&= \frac{\left(\frac{2}{3} \times 3\right)}{\frac{5}{4} \times 3} \\ &= \frac{\frac{2}{15}}{4}\end{aligned}$$

We still have a compound fraction. The denominator of the bottom fraction is 4 – so now we will multiply both the numerator and denominator by 4.

$$\begin{aligned}&= \frac{\frac{2 \times 4}{15}}{4 \times 4} \\ &= \frac{8}{15}\end{aligned}$$

Let's check if we get the same answer with the shortcut we know:

$$\begin{aligned}\frac{2}{5} \div \frac{3}{4} \\ &= \frac{2}{5} \times \frac{4}{3} \\ &= \frac{8}{15} \text{ ☺}\end{aligned}$$

This still doesn't explain why it works. Let's have a closer look at what was actually done in the longer version of the calculation:

$$\frac{2}{5} \div \frac{3}{4} = \frac{(2 \div 3 (\times 3 \times 4))}{(5 \div 4 (\times 3 \times 4))} = \frac{8}{15}$$

With a knowledge of inverse operations, we know that $\div 3$ and $\times 3$ are inverse operations so they 'cancel' each other out. If you divide by 3 then multiply by 3 you will be back where you started. $\div 4$ and $\times 4$ are also inverse operations.

Let's look at what happens when we take these out of the above equation:

$$\frac{2}{5} \div \frac{3}{4} = \frac{(2 \times 4)}{(5 \times 3)} = \frac{2}{5} \times \frac{4}{3} \text{ which is what is known as the 'shortcut!'}$$

TOPIC 2: DECIMAL FRACTIONS

INTRODUCTION

- This unit runs for 9 hours.
- This unit falls under the Outcome, Numbers, Operations and Relationships.
- This outcome counts for 30% of the final exam.
- This unit covers concepts and skills required for finance that is taught later in high school. These concepts are also expanded on in the senior phase, when algebraic concepts are included. The concepts increase in complexity and learners need to learn the rules in order to apply them to solve equations.
- It is important for the learners to understand how to apply the rules, in order to apply them in solving equations later in the senior phase, and into the FET phase.
- Remember that it is important to reinforce mental calculations across the four basic operations wherever possible, throughout each section of the topic.

SEQUENTIAL TEACHING TABLE

INTERMEDIATE PHASE / GRADE 6	GRADE 7	GRADE 8 SENIOR PHASE / FET PHASE
LOOKING BACK	CURRENT	LOOKING FORWARD
<ul style="list-style-type: none"> • Recognizing, ordering and place value of decimal fractions • Count forwards and backwards in decimal fractions to at least two decimal places • Compare and order decimal fractions to at least two decimal places • Place value of digits to at least two decimal places • Calculations with decimal fractions • Addition and subtraction of decimal fractions with at least two decimal places • Multiply decimal fractions by 10 and 100 • Solve problems in context involving decimal fractions • Recognize equivalence between common fraction and decimal fraction forms of the same number • Recognize equivalence between common fraction, decimal fraction and percentage forms of the same number 	<ul style="list-style-type: none"> • Revising all concepts from Grade 6 • Division and multiplication of decimals by other decimals. 	<ul style="list-style-type: none"> • Revise the following done in Grade 6 and 7 and applying these skills to algebraic contexts: • Division and multiplication of decimals by other decimals • Recognizing, ordering and place value of decimal fractions • Count forwards and backwards in decimal fractions to at least two decimal places • Compare and order decimal fractions to at least two decimal places • Place value of digits to at least two decimal places • Calculations with decimal fractions • Addition and subtraction of decimal fractions with at least two decimal places • Multiply decimal fractions by 10 and 100 • Solve problems in context involving decimal fractions • Recognize equivalence between common fraction and decimal fraction forms of the same number • Recognize equivalence between common fraction, decimal fraction and percentage forms of the same number

GLOSSARY OF TERMS

Term	Explanation / Diagram
Decimal Number	This is a number that has a decimal comma that is used to separate whole parts of the number, from the parts that are represented over a multiple of 10.
Decimal Place	The position of a digit to the right of a decimal point. Each successive position to the right has a denominator of an increased power of 10.
Place Value	The value a digit has due to its specific place in the number.
Rounding Off	Reducing the number of decimal places according to the instruction or the convention that is being worked with. To round off correctly, look at the first digit that will not be used in the final answer; if it is 5 or greater then we round up; if it is 4 or less we round down.
Tip and Times	Inverting the fraction after a divide sign, so that we can simplify by changing the division into a multiplication sign.
Reciprocal	This is the multiplicative inverse of any number. If the product of two numbers is 1, then they are reciprocals of each other.
Equivalent Fractions	Fractions are equivalent if they reduce to the same simplified fraction. Equivalent fractions are equal in value.
Mixed Numbers / Mixed Fractions	An improper fraction written partly as a whole number and partly as a proper fraction.

SUMMARY OF KEY CONCEPTS

Reading and Writing Decimal Fractions

Learners must be able to correctly read and write decimal fractions. Learners ought to know the correct name and placement according to the place value of the digit they are given.



EXAMPLE:

Numbers such as **9205,354** and **28,4531**

Thousands	Hundreds	Tens	Units	Decimal comma	tenths	hundredths	thousandths	ten thousandths
9	2	0	5	,	3	5	4	
		2	8	,	4	5	3	1

This table can be extended further in both directions. It would be useful for learners to draw the table in their books until they have grasped the concept completely.

Learners need to be reminded that 28,35 is read as twenty-eight comma three five and NOT as twenty-eight comma thirty five.

Rounding off of Decimal Fractions

Rounding is an important concept and learners must understand how to round off correctly.

When rounding a decimal, the interest is in the digit to the right of where the rounding requirement is (so if required to round to two decimal places, the digit in the third place is of importance).

If that digit is 5 or higher, the digit in the correct position is rounded UP. If that digit is 4 or smaller, the digit remains as it is.



EXAMPLE:

0,31425

Rounded to 2 decimal places: 0,31

Rounded to 4 decimal places: 0,3143

(4 is in the 3rd – thousandth – position so leave the digit in the 2nd position as it is)

(5 is in the 5th position so round the digit in the 4th position '2' up to 3)

Topic 2 Decimal Fractions

Compare and Order Decimal Fractions

Use decimal fraction place value columns to compare decimal fractions.



EXAMPLE:

Compare 0,534 and 0,552

Units	Decimal comma	tenths	hundredths	Thousandths
0	,	5	3	4
0	,	5	5	2

Looking at the units and tenths the numbers seem similar, but then looking at the hundredths reveals that 0,552 is the bigger decimal number.

The numbers must be compared from the left to the right.



Teaching Tip: Decimals can only be compared if they contain the same number of decimal places. Learners must top up with zeros until the decimal numbers contain the same number of decimal places. Learners often forget to put a zero if it is required at the end of a decimal. This can often be seen in calculations involving money, therefore the rule must be reinforced as that zero is important.

Equivalent Forms

This section is identical to the previous section covered as part of common fractions. Refer back to that section and look at the resources provided to see the relationship between fractions in various forms. (RESOURCE 2 from topic 1)

Addition and Subtraction of Decimal Fractions

1. The simplest way to add or subtract decimals is in columns (vertically). The decimal signs must be exactly underneath each other so that the place values match. (Tens underneath Tens, hundredths underneath hundredths and so on). If need be, zeroes can be placed at the end, to make the decimal fractions the same 'length'.

EXAMPLES:

a. $3,2 + 1,45$

$$\begin{array}{r} 3,20 \\ + 1,45 \\ \hline 4,65 \end{array}$$



b. $4,291 + 5,64$ (carrying over required)

$$\begin{array}{r} 4,291 \\ + 5,640 \\ \hline 9,931 \end{array}$$

c. $5,12 - 2,452$ (borrowing is required)

$$\begin{array}{r} 5,120 \\ - 2,452 \\ \hline 2,668 \end{array}$$



Teaching Tip: Learners need to be reminded to take care to place the decimal commas correctly underneath each other when they need to perform various operations. It really does help to use a place value table, or to get learners to draw columns until they have mastered this technique.

Multiplication of Decimal Fractions

1. Multiplying by powers of 10.

This is very easy to do - for every 10 being multiplied by, the digits move one place to the left.

Remember to check that the number has become larger (as it should when multiplying).



EXAMPLES:

$$3,21 \times 10 = 32,1$$

$$4,192 \times 100 = 419,2$$



Teaching Tip: Learners must realise that the comma is a FIXED point, and that only the digits move -and not the comma- when multiplied by multiples of 10. The digits move to the left of the decimal place as the number gets bigger.

2. Multiplication of decimals by integers.

The method of multiplying in columns (vertically) is still the preferred method as it eliminates the possibility of errors. While in the process of multiplying, ignore any decimal signs. Once the multiplication is complete, count the total number of digits after the decimal sign in the decimal fraction – this is how many places there should be in the answer. Insert the decimal to make this correct.

Topic 2 Decimal Fractions



EXAMPLE:

$$4,62 \times 3$$

$$\begin{array}{r} 462 \\ \times \quad 3 \\ \hline 1386 \end{array} \quad \begin{array}{l} \therefore 4,62 \times 3 = 13,86 \text{ (two decimal places in the question)} \\ \therefore \text{two decimal places in the answer} \end{array}$$

3. Multiplication of decimal fractions by decimal fractions.

The vertical method is used again.

While in the process of multiplying, ignore any decimal signs.

Once the multiplication is complete, count the total number of digits after the decimal sign in both decimal fractions – this is how many places there should be in the answer.

Insert the decimal to make this correct.



EXAMPLE:

$$2,43 \times 0,6$$

$$\begin{array}{r} 243 \\ \times \quad 6 \\ \hline 1458 \end{array}$$

As there are 3 digits after the decimal signs in total (2 in 2,43 and 1 in 0,6), there needs to be 3 in the final answer.

$$\therefore 2,43 \times 0,6 = 1,458$$



Teaching Tip: Encourage learners to count all digits that come after the decimal sign(s) before they start the multiplication. Learners should also be encouraged to write down how many decimal digits there are on the side, so that they know/remember to insert the decimal point in the answer.

Division of Decimal Fractions

1. Dividing by powers of 10.

This is very easy to do - for every 10 being divided by, the digits move one place to the right.

Remember to check that the number has become smaller (as it should when dividing).



EXAMPLES:

$$34,21 \div 10 = 3,421$$

$$34,21 \div 100 = 0,3421$$

$$34,21 \div 1000 = 0,03421$$



Teaching Tip: Learners must realise that the comma is a FIXED point and that only the digits move -and not the comma- when divided by multiples of 10. The digits move to the right of the comma as the number gets smaller.

2. Dividing decimals by integers.

Divide using short or long division, keeping the decimal in the same position for the answer (quotient) as it is in the question.

Add zeroes to the end of the decimal if necessary, until there is no remainder.



EXAMPLE:

$$48,24 \div 3$$

$$\begin{array}{r} 16,08 \\ 3 \overline{)48,24} \end{array}$$

3. Dividing decimals by decimals.

In order to do this, both decimals in the question must be multiplied by the same number of 10's, until the divisor (what is being divided by) is an integer, then follow the steps above.



EXAMPLE:

$$0,62 \div 0,2$$

(In order to make sure there is division by an integer, both sides need to be multiplied by 10.)

$$= 6,2 \div 2$$

$$= 3,1$$



Teaching Tip: Introducing decimals in the context of money does help to make the concept easier to explain. Using money also helps to explain the importance of the zero in decimals. For example, R59,50 and not R59,5.

TOPIC 3: FUNCTIONS AND RELATIONSHIPS

INTRODUCTION

- This unit runs for 3 hours.
- This unit falls under the Outcome, Patterns, Functions and Algebra.
- This outcome counts for 25% of the final exam.
- This unit covers concepts and skills that are essential for Algebra later in the senior phase, and becomes the foundation for functions and graphs that are also covered later in the senior phase, and throughout the FET phase of school.
- It is important for the learners to be able to use a variety of methods to determine input, output and even to determine the rule or function. This section also lends itself to the introduction of equations and solving equations.
- Remember, it is important to reinforce mental calculations across the four basic operations wherever possible, throughout each section of the topic.

SEQUENTIAL TEACHING TABLE

INTERMEDIATE PHASE / GRADE 6	GRADE 7	GRADE 8 SENIOR PHASE/ FET PHASE
LOOKING BACK	CURRENT	LOOKING FORWARD
<p>Determine equivalence of different descriptions of the same relationship or rule presented</p> <ul style="list-style-type: none"> • verbally • in a flow diagram • in a table • by a number sentence <p>Determine input values, output values and rules for the patterns and relationships using:</p> <ul style="list-style-type: none"> • flow diagrams • tables 	<p>Determine equivalence of different descriptions of the same relationship or rule presented</p> <ul style="list-style-type: none"> • verbally • in a flow diagram • in a table • by a number sentence <p>Determine input values, output values and rules for the patterns and relationships using:</p> <ul style="list-style-type: none"> • flow diagrams • tables • formulae 	<p>Determine equivalence of different descriptions of the same relationship or rule presented</p> <ul style="list-style-type: none"> • verbally • in a flow diagram • in a table • by a number sentence <p>Determine input values, output values and rules for the patterns and relationships using:</p> <ul style="list-style-type: none"> • flow diagrams • tables • formulae • equations

GLOSSARY OF TERMS

Term	Explanation / Diagram
Number Sentence	An expression representing a rule to be performed on the variable.
Input	The number/value that was chosen to replace the variable in an expression.
Output	The output is dependent on the input – it is the answer once the operation has been performed according to the expression given.
Equation	A mathematical sentence built from an algebraic expression using an equal sign.
Flow Diagram	A diagram representing a sequence of movements to be performed on a given value.
Variable	A letter used to replace a number that can represent a variety of different values.
Constant	A value that remains the same and does not vary.

SUMMARY OF KEY CONCEPTS

Number Sentences and Variables

This section is the introduction to the skill of solving equations. These are the calculations that are used to determine the different outcomes when the input value is varied.

These are word problems changed from words into “sums” that are then calculated.



EXAMPLE:

Five primary schools each get 5 new learners in Grade 7. The table below gives the original number of learners each school had in Grade 7. How many learners does each school have now?

School 1	School 2	School 3	School 4	School 5
134	154	98	102	57

NUMBER SENTENCE: Original number of learners plus 5 equals
(or $a + 5 =$, where a is the original number of learners).

- School 1: $134 + 5 = 139$
- School 2: $154 + 5 = 159$
- School 3: $98 + 5 = 103$
- School 4: $102 + 5 = 107$
- School 5: $57 + 5 = 62$

Flow Diagrams

1. A flow diagram with one operation:

Remember that this can now include calculations with decimals and fractions. Each value passes through the rule or process and is changed.

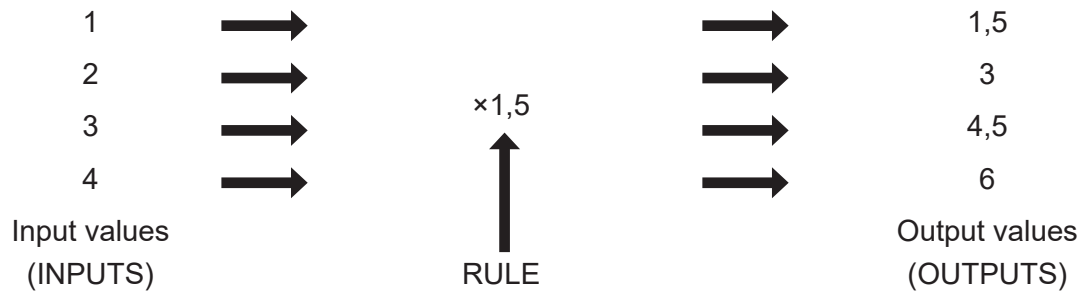

Number sentences for this flow diagram

$$1 \times 1,5 = 1,5 \quad 2 \times 1,5 = 3 \dots$$

2. A flow diagram with multiple operations:

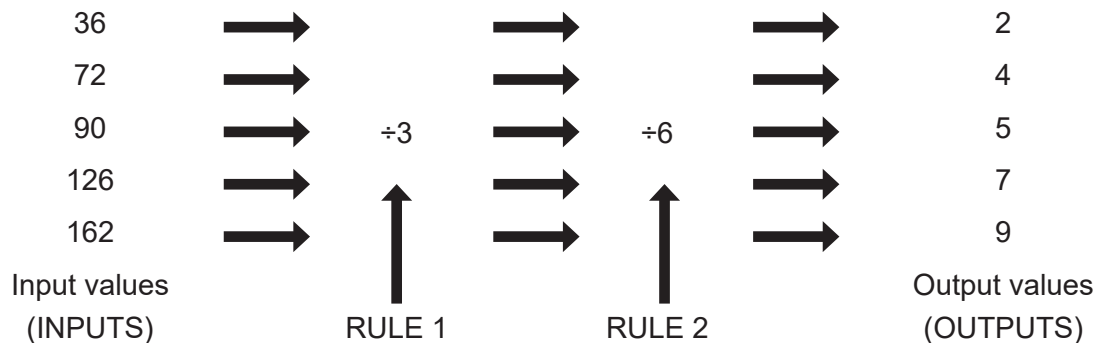

Relationships in a Table

In a table, learners must be able to determine the input and output values as they would for a flow diagram.

	1	2	3	4	5	6	7	8
x 2	2	4	6	8	10	12	14	16
+ 3	5	7	9	11	13	15	17	19

Number sentences for this table

$$1 \times 2 + 3 = 5 \quad 2 \times 2 + 3 = 7 \dots$$

Topic 3 Functions and Relationships

Finding the Rule

Learners should be able to determine the rule that is used to find the output values in a table, or in a flow diagram. Learners must be able to look at the input and output values, and determine the rule that satisfies the number sentence.



Teaching Tip: The idea is not for learners to learn any special methods, but for them to rather use inspection and trial and error to determine the working rule or process. Learners must describe the same relationship in many different ways.

TOPIC 4: AREA AND PERIMETER OF 2D SHAPES

INTRODUCTION

- This unit runs for 7 hours.
- This unit falls under the Outcome, Shape and Space.
- This outcome counts for 25% of the final exam.
- This unit covers concepts that are required for measurement throughout the rest of the senior and FET phase. Concepts such as Area and Perimeter become the base of the concepts that are taught in the next section related to 3D shapes.
- It is important for the learners to be taught a variety of methods that they can use to suit their needs for these calculations. Learners who become too dependent on formulae battle to deal with shapes that are combined or irregular. In Grade 6, learners were not expected to know formulae for calculations, however in Grade 7, formulae are vital and must be taught.
- Remember, it is important to reinforce mental calculations across the four basic operations wherever possible, throughout each section of the topic.

SEQUENTIAL TEACHING TABLE

INTERMEDIATE PHASE / GRADE 6	GRADE 7	GRADE 8 SENIOR PHASE / FET PHASE
LOOKING BACK	CURRENT	LOOKING FORWARD
<ul style="list-style-type: none"> • Measure perimeter using rulers or measuring tapes • Continue to find areas of regular and irregular shapes by counting squares on grids • Develop rules for calculating the areas of squares and rectangles • Relationship between perimeter and area of rectangles and squares. 	<ul style="list-style-type: none"> • Calculate the perimeter of regular and irregular polygons • Use appropriate formulae to calculate perimeter and area of: <ul style="list-style-type: none"> • squares • rectangles • triangles • Solve problems involving perimeter and area of polygons • Calculate to at least 1 decimal place • Use and convert between appropriate SI units, including: <ul style="list-style-type: none"> • $\text{mm}^2 \leftrightarrow \text{cm}^2$ • $\text{cm}^2 \leftrightarrow \text{m}^2$ 	<ul style="list-style-type: none"> • Use appropriate formulae and conversions between SI units, to solve problems and calculate perimeter and area of: <ul style="list-style-type: none"> • polygons • circles • Investigate how doubling any or all of the dimensions of a 2D figure affects its perimeter and its area • Calculate to at least 2 decimal places • Use and describe the meaning of the irrational number Pi [π] in calculations involving circles • Use and convert between appropriate SI units, including: $\text{mm}^2 \leftrightarrow \text{cm}^2 \leftrightarrow \text{m}^2 \leftrightarrow \text{km}^2$

GLOSSARY OF TERMS

Term	Explanation / Diagram
Two-dimensional (2D)	The name given to flat shapes that occupy a space and thus have area that can be calculated.
Regular Polygon	A polygon whose sides are all the same length, and whose angles are all the same size.
Irregular Polygon	A polygon that does not have sides that are the same length, nor are the angles the same size.
Equilateral	A shape that is equilateral has all its sides the same length.
Perimeter	The distance around a polygon.
Formula	An expression or equation that is used to express the relationship between certain quantities.
Standard Unit (SI Unit)	A unit is the standard quantity which is used to measure other quantities.
Area	The surface of a shape or object. It can also be defined as the number of square units that a shape covers.
Composite Shape	An irregular shape that is made up of parts or whole components of other shapes.

SUMMARY OF KEY CONCEPTS

Perimeter

Perimeter is a distance and therefore a linear measurement. The unit of measurement used would depend on the size of the shape.

For example:

A swimming pool's perimeter would be measured in metres (m) but a piece of paper's perimeter would be measured in centimetres (cm) or millimetres (mm).

Area

Area deals with 2-dimensional shapes and therefore the measurement is always in 'squared'. When dealing with area, we are calculating the amount of space a 2D shape takes up.

Squares

To find the perimeter of a square, all 4 sides are added together.

For example:

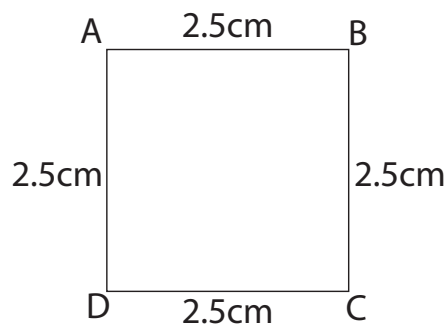

$$\begin{aligned}\text{Perimeter} &= 2,5\text{cm} + 2,5\text{cm} + 2,5\text{cm} + 2,5\text{cm} \\ &= 4(2,5\text{ cm}) \\ &= 10\text{ cm}\end{aligned}$$

Topic 4 Area and Perimeter of 2D Shapes

To find the area of a square the length is multiplied by the breadth. As these are the same measurements it could also be said that the length is squared.

For example:

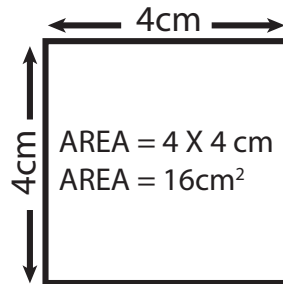

Rectangles

To find the perimeter of a rectangle, all 4 sides are added together.

For example:

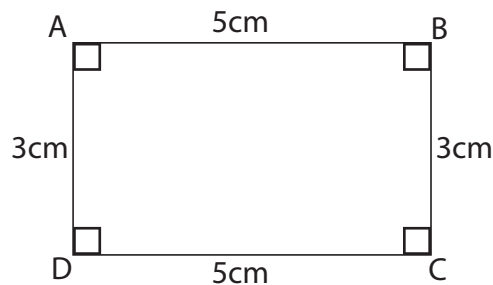

$$\begin{aligned}\text{Perimeter} &= 5\text{cm} + 5\text{cm} + 3\text{cm} + 3\text{cm} \\ &= 2(5\text{cm}) + 2(3\text{cm}) \\ &= 10\text{ cm} + 6\text{cm} \\ &= 16\text{cm}\end{aligned}$$

To find the area of a rectangle the length is multiplied by the breadth.

For example:

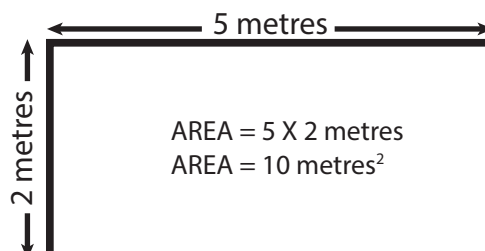

Topic 4 Area and Perimeter of 2D Shapes

Triangles

To find the perimeter of a triangle, all 3 sides are added together.

For example:

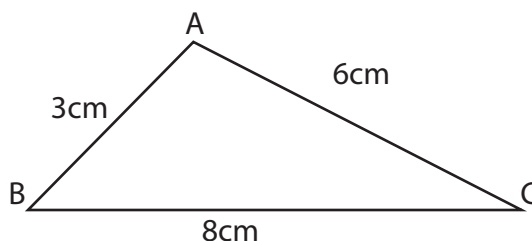

$$\begin{aligned}\text{Perimeter} &= 3\text{cm} + 6\text{cm} + 8\text{cm} \\ &= 17\text{cm}\end{aligned}$$

To find the area of a triangle, the base is multiplied by the perpendicular height then multiplied by half.

This formula comes from the use of area of a rectangle.

The following 2 diagrams demonstrate this:

Area of rectangle = $b.h$

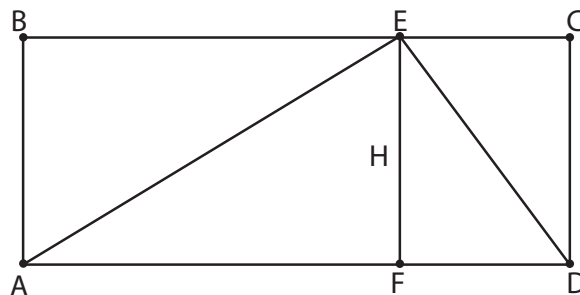
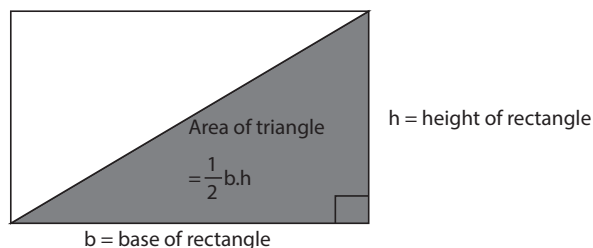

Note in this diagram that AD would be the length of the rectangle as well as the base of the

triangle and 'h' would be the breadth/width of the rectangle as well as the height of the triangle. Multiplying the base and height would give the area of the rectangle.

Topic 4 Area and Perimeter of 2D Shapes

Halving this answer would give the area of the triangle. ($\triangle ECD$ is the same size as $\triangle DEF$ and $\triangle ABE$ is the same size as $\triangle AEF$)

For example:

$$\begin{aligned}\text{Area} &= \frac{1}{2} \times \text{base} \times \text{perpendicular height} \\ &= \frac{1}{2} \times 11 \times 10 = 55 \text{ cm}^2\end{aligned}$$

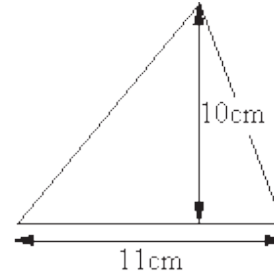

In an obtuse-angled triangle, the height is measured outside the triangle:

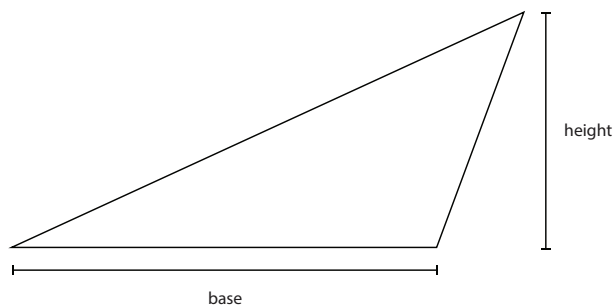

In a right-angled triangle, the base and height are the two sides that form the right angle:

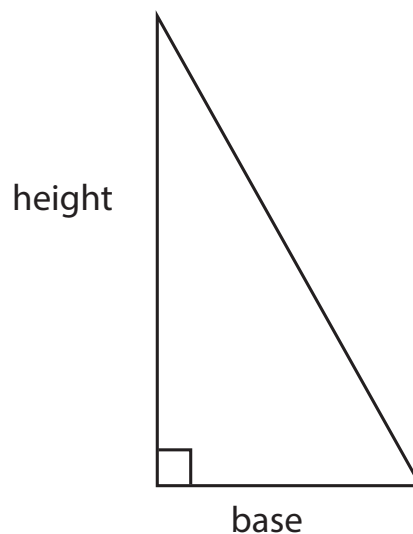

Topic 4 Area and Perimeter of 2D Shapes

Finding area and perimeter of complex shapes

Learners must be able to determine that area of regular and irregular polygons.

When dealing with more unusual shapes, they need to be broken up into one or more of the more familiar shapes in order to find the area or the perimeter of them.

For example:

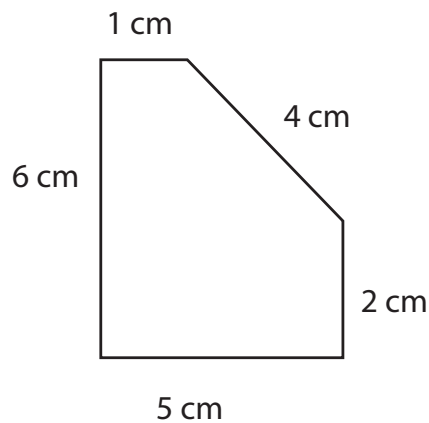

Note that this shape could be broken up into a rectangle at the bottom (5cm by 2cm) and a rectangle on the top left (1cm by 4cm because the 2cm from the previously mentioned rectangle has been taken away from the 6cm) and a triangle with a base of 4cm (the 1cm has been taken away from the top measurement) and height of 4cm to match the 2nd rectangle.

This is not the only possible way to break this irregular shape up. Perhaps you can find another way?

In this case, perimeter is quite simple as it just requires adding up all the measurements that can be seen. It is possible in another question that the Theorem of Pythagoras may need to be used.

$$\begin{aligned}\text{Area} &= (5\text{cm})(2\text{cm}) + (1\text{cm})(4\text{cm}) + \frac{1}{2}(4\text{cm})(4\text{cm}) \\ &= 10\text{cm}^2 + 4\text{cm}^2 + 8\text{cm}^2 \\ &= 22\text{cm}^2\end{aligned}$$

$$\begin{aligned}\text{Perimeter} &= 1\text{cm} + 6\text{cm} + 5\text{cm} + 2\text{cm} + 4\text{cm} \\ &= 18\text{cm}\end{aligned}$$

Conversions of SI Units

Learners must be taught the conversions within the metric system. They must know these conversions and must be able to convert from smaller to bigger units, as well as from bigger to smaller units.

When we convert to a larger unit, we **multiply** by the conversion factor.

When we convert to a smaller unit, we **divide** by the conversion factor.

Linear Conversions

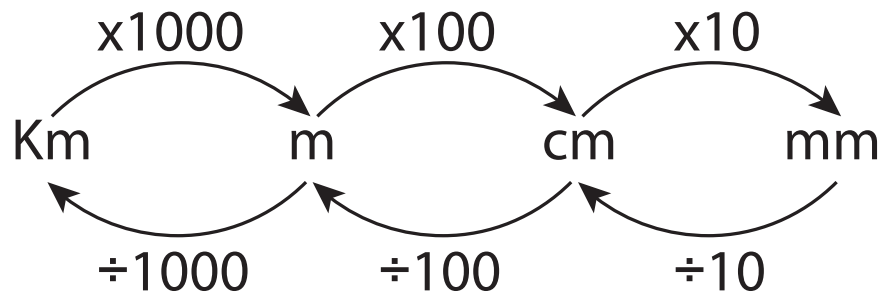

EXAMPLE:

Convert the following measurements to the units indicated:

1. 7 cm to mm
2. 8 m to cm
3. 9 km to m
4. 975 m to km
5. 650 cm to m
6. 8000 mm to m
7. 950 000 cm to km

Topic 4 Area and Perimeter of 2D Shapes

Solution:

$$\begin{aligned} 1. \quad 7 \text{ cm} &= 7 \times 10 \text{ mm} && (1 \text{ cm} = 10 \text{ mm}) \\ &= 70 \text{ mm} \end{aligned}$$

$$\begin{aligned} 2. \quad 8 \text{ m} &= 8 \times 100 \text{ cm} && (1 \text{ m} = 100 \text{ cm}) \\ &= 800 \text{ cm} \end{aligned}$$

$$\begin{aligned} 3. \quad 9 \text{ km} &= 9 \times 1000 && (1 \text{ km} = 1000 \text{ m}) \\ &= 9000 \text{ m} \end{aligned}$$

$$\begin{aligned} 4. \quad 975 \text{ m} &= \frac{975}{1000} \text{ Km} && (1000 \text{ m} = 1 \text{ Km}) \\ &= 0,975 \text{ Km} \end{aligned}$$

$$\begin{aligned} 5. \quad 650 \text{ cm} &= \frac{650}{100} \text{ m} && (100 \text{ cm} = 1 \text{ m}) \\ &= 6,5 \text{ m} \end{aligned}$$

$$\begin{aligned} 6. \quad 8000 \text{ mm} &= \frac{8000}{10} \text{ cm} && (10 \text{ mm} = 1 \text{ cm}) \\ &= 800 \text{ cm} \\ &= \frac{800}{100} \text{ m} && (100 \text{ cm} = 1 \text{ m}) \\ &= 8 \text{ m} \end{aligned}$$

$$\begin{aligned} 7. \quad 950\,000 \text{ cm} &= \frac{950\,000}{100} \text{ m} && (100 \text{ cm} = 1 \text{ m}) \\ &= 9500 \text{ m} \\ &= \frac{9500}{1000} \text{ Km} && (1000 \text{ m} = 1 \text{ Km}) \\ &= 9,5 \text{ Km} \end{aligned}$$

Area Conversions

When converting area measurements, it isn't as straightforward as multiplying or dividing by 10, 100 or 1000 as it is for linear measurements.



Consider this square:

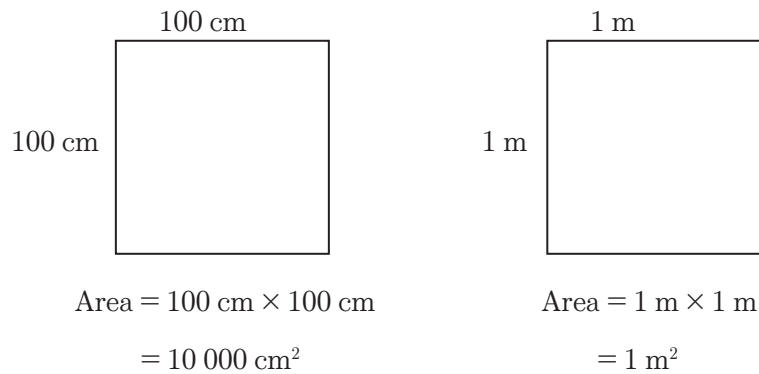

Since 1m = 100cm, these squares are the same size, so therefore

$$10\,000\text{ cm}^2 = 1\text{ m}^2$$

Normally, we would think of the conversion 1 m = 100 cm, but since we are dealing with area we need to remember that:

$$1\text{ m}^2 = 100\text{ cm} \times 100\text{ cm} = 10\,000\text{ cm}^2$$

Converting AREA Units

area consists of square units, so we need to SQUARE all our lengths

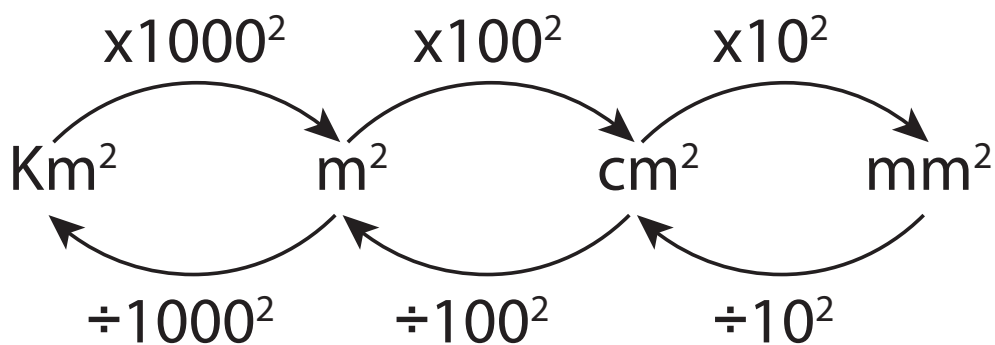

Topic 4 Area and Perimeter of 2D Shapes



Example:

Convert the following measurements to the units indicated:

1. 100m^2 to cm^2
2. $10\,000\text{cm}^2$ to m^2
3. 1m^2 to mm^2
4. $1\,000\text{mm}^2$ to cm^2

Solutions:

1. 100m^2 to cm^2
 $(\times 100^2)$
 $(100 \times 100 \times 100)\text{cm}^2$
 $= 1\,000\,000\text{cm}^2$
2. $10\,000\text{cm}^2$ to m^2
 $(\div 100^2)$
 $(10\,000 \div 100 \div 100)\text{m}^2$
 $= 1\text{m}^2$
3. 1m^2 to mm^2
 $(\times 100^2 \times 10^2)$
 $(1 \times 100 \times 100 \times 10 \times 10)\text{mm}^2$
 $= 1\,000\,000\text{mm}^2$
4. $1\,000\text{mm}^2$ to cm^2
 $(\div 10^2)$
 $(1\,000 \div 10 \div 10)\text{cm}^2$
 $= 10\text{cm}^2$

TOPIC 5: SURFACE AREA AND VOLUME OF 3D OBJECTS

INTRODUCTION

- This unit runs for 8 hours.
- This falls under the Outcome, Shape and Space.
- This outcome counts for 25% of the final exam. This section is covered in stages, and continues to expand in the later stages of the senior phase, and then combines with an algebra component in the FET phase.
- This unit covers concepts and skills that are required to determine surface area and volume, and is therefore an extension of the previous unit. It is very important that learners have fully grasped the previous unit before moving on to this unit.
- Mental maths focussing on the understanding of the previous unit must be practiced at the start of every lesson relating to this section.

SEQUENTIAL TEACHING TABLE

INTERMEDIATE PHASE / GRADE 6	GRADE 7	GRADE 8 SENIOR PHASE/ FET PHASE
LOOKING BACK	CURRENT	LOOKING FORWARD
<ul style="list-style-type: none"> Investigate the relationship between surface area and volume of rectangular prisms Develop an understanding of why the volume of rectangular prisms is given by length multiplied by width multiplied by height Continue to find volume/capacity of objects by packing or filling them 	<ul style="list-style-type: none"> Use appropriate formulae to calculate the surface area, volume and capacity of: <ul style="list-style-type: none"> cubes rectangular prisms Describe the interrelationship between surface area and volume of the objects mentioned above Solve problems involving surface area, volume and capacity Use and convert between appropriate SI units, including: <ul style="list-style-type: none"> $\text{mm}^2 \leftrightarrow \text{cm}^2$ $\text{cm}^2 \leftrightarrow \text{m}^2$ $\text{mm}^3 \leftrightarrow \text{cm}^3$ $\text{cm}^3 \leftrightarrow \text{m}^3$ Use equivalence between units when solving problems: <ul style="list-style-type: none"> $\text{cm}^3 \leftrightarrow 1 \text{ ml}$ $1 \text{ m}^3 \leftrightarrow 1 \text{ kl}$ 	<ul style="list-style-type: none"> Use appropriate formulae and conversions <ul style="list-style-type: none"> between SI units to solve problems and calculate the surface area, volume and capacity of: <ul style="list-style-type: none"> cubes rectangular prisms triangular prisms cylinders Investigate how doubling any or all the dimensions of right prisms and cylinders affects their volume Solve problems, with or without a calculator involving surface area, volume and capacity Use and convert between appropriate SI units, including: <ul style="list-style-type: none"> $\text{mm}^2 \leftrightarrow \text{cm}^2$ $\text{cm}^2 \leftrightarrow \text{m}^2$ $\text{mm}^3 \leftrightarrow \text{cm}^3$ $\text{cm}^3 \leftrightarrow \text{m}^3$ Use equivalence between units when solving problems: <ul style="list-style-type: none"> $\text{cm}^3 \leftrightarrow 1 \text{ ml}$ $1 \text{ m}^3 \leftrightarrow 1 \text{ kl}$ All of these applications must be well enough developed to be combined with algebraic context in the FET phase.

GLOSSARY OF TERMS

Term	Explanation / Diagram
Solid Figure	A 3D shape that has length, breadth and height (or depth).
Polygonal	A closed figure that has three or more sides, also known as a polygon.
Cube	A 3D figure with 6 identical square faces.
Prism	A solid object with 2 identical ends and flat sides. The cross section is the same all along the length.
Rectangular Prism	A prism made of 6 rectangular faces.
Pyramid	A special type of polyhedron. It has a polygon base and the other faces are triangles that meet at an apex.
Polyhedron	A solid figure that has polygons as its faces. A prism is also known as a polyhedron.
3 dimensional (3D)	These are figures that do not lie in a plane. The figures have length, breadth and height or depth.
Face	The flat surface or side of a solid shape.
Edge	The edges are the intersections of the faces of a solid figure.
Vertex	The corner of a solid shape. The point where the edges meet.
Apex	The highest point or peak of a pyramid.
Surface Area	The sum of the areas of each of the faces of a 3D shape.
Volume	The amount of space contained inside a shape. That means volume is the space that can be filled with other items. Volume is measured in cubic units.
Capacity	The amount of liquid that a 3D shape can hold. It is measured in ml or l.
Net	A 2D pattern that folds to form a 3D shape. It is helpful when calculating surface area as it makes all faces visible, so that they are not omitted from the calculation.

SUMMARY OF KEY CONCEPTS

Solids

Learners must be introduced to the solid shapes that they will be working with, and it is important that physical examples are shown to learners. Shapes can be simple, and examples include items such as dice, Coke cans, Smartie boxes or even Toblerone boxes. Have the learners flatten and explore these shapes. Toilet rolls and paper towel rolls can be used as cylinders, and this helps learners see the relationship with rectangles.

Learners must recognise that 3D shapes are made up of basic 2D shapes in a net folded to form the solid shape.

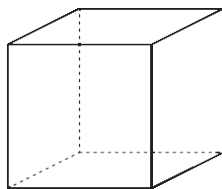

cube

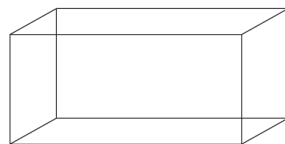

rectangular prism

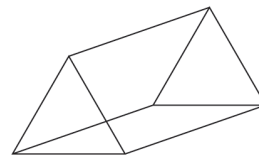

triangular prism

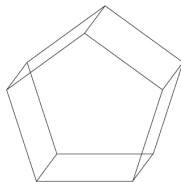

pentagonal prism

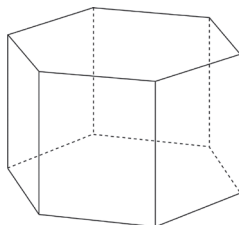

hexagonal prism

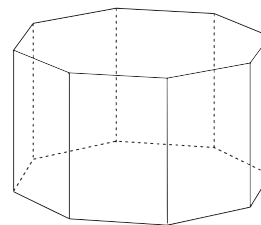

octagonal prism

Surface Area of 3D shapes

1. The term 'surface area' is linked to 3-dimensional objects only. (When dealing with 2-dimensional shapes the term 'area' is used)
2. The answer will always be in measurement squared. For example, cm^2
3. To find the surface area of a 3D object is to find the total area taken up by the net of the 3D shape (what the 3D shape looks like in its flattened form)

For example: A box looks like this in its 3D form



But it will look like this in its flattened out 2D form
(this is the net of a rectangular prism)

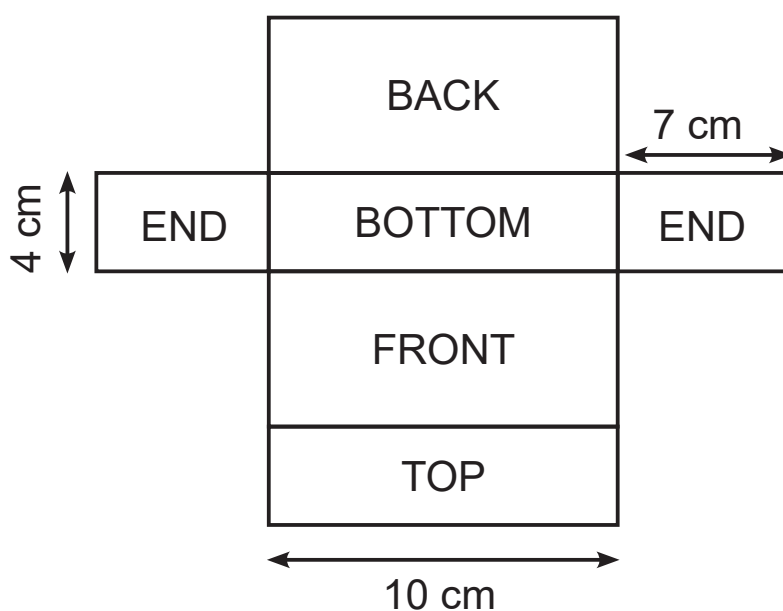

It is best not to try and learn the formulae for surface area of solid shapes but to rather ensure you know what the net of the shape looks like and know how to find the area of the 2D shapes that make up the net (square, rectangle and triangle). The surface area of the 3D shape would then be those added together.

Topic 5 Surface Area and Volume of 3D Objects

SHAPE	AREA FORMULA
Square	$l \times l = l^2$
Rectangle	$l \times b$

Consider the box again. It is made up of 6 rectangles. To find the surface area you will need to find the area of each of these rectangles, then add all of them together.

The length is 10cm, the breadth is 4cm and the height is 7cm. However, notice that the front and back are the same size, as are the top and bottom and the two sides.

The Surface Area of the rectangular prism can be found by:

$$\begin{aligned} & 2(l)(b) + 2(l)(h) + 2(b)(h) \\ & = 2(10\text{cm})(4\text{cm}) + 2(10\text{cm})(7\text{cm}) + 2(4\text{cm})(7\text{cm}) \\ & = 80\text{cm}^2 + 140\text{cm}^2 + 56\text{cm}^2 \\ & = 276\text{cm}^2 \end{aligned}$$

Volume of 3D shapes

1. The term 'volume' is linked to 3-dimensional objects only.
2. The answer will always be in measurement cubed because three dimensions are being multiplied. For example cm^3
3. To find the volume of any right prism, the basic formula is:
Area of base x perpendicular height

Notice again that you are required to know how to find the area of the basic shapes (square, rectangle and later on a triangle).

VOLUME OF:	AREA OF BASE x HEIGHT
Cube	$[(l \times l) \times ht]$ $= l \times l \times l$ $= l^3$
Rectangular prism [cuboid]	$[(l \times b) \times h]$ $= lbh$

For example:

a.

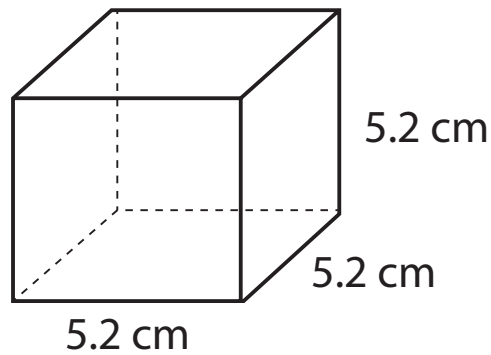

To find the volume of a cube, the area of the base is multiplied by the height. As these measurements are all equal it is the same as cubing the measurement.

$$\begin{aligned}\text{Volume} &= (l \times b) \times h \\ &= l^3 \\ &= (5,2\text{mm})^3 \\ &= 140,61 \text{ mm}^3\end{aligned}$$

b.

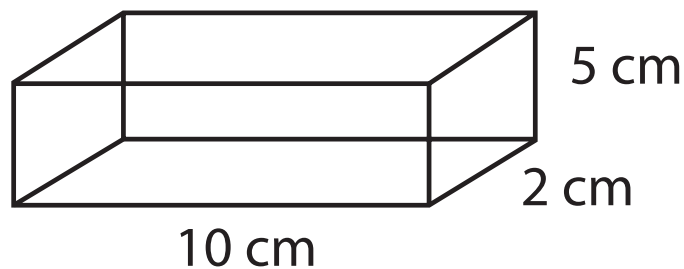

To find the volume of this rectangular prism (or cuboid), we need to find the area of the base (a rectangle) and multiply it by the height. These three dimensions is what gives us the 'cubed' in the answer.

$$\begin{aligned}\text{Volume} &= (l \times b) \times h \\ &= (10 \text{ cm} \times 2 \text{ cm}) \times 5 \text{ cm} \\ &= 100 \text{ cm}^3\end{aligned}$$

Topic 5 Surface Area and Volume of 3D Objects

Capacity of 3D shapes

1. Capacity is how much liquid a 3D shape (solid) can hold. It is directly linked to volume.
2. The following three conversions should be learnt:

$$\begin{aligned}1 \text{ cm}^3 &= 1 \text{ ml} \\ 1000 \text{ cm}^3 &= 1000 \text{ ml} = 1 \text{ l} \\ 1 \text{ m}^3 &= 1000 \text{ l} = 1 \text{ kl}\end{aligned}$$

3. For example:

A teaspoon holds 5 millilitres. This means its size is 5 cm^3

A carton of fruit juice holds 1 litre (1 000 millilitres). This means its size is $1\,000 \text{ cm}^3$.

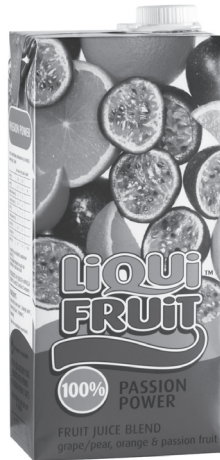

4. A large fish tank has the following dimensions: 110cm, 45cm and 60cm



Find how many litres of water the tank can hold.

First we need to find the volume:

$$\begin{aligned}\text{Volume} &= (l \times b) \times h \\ &= (110\text{cm} \times 45\text{cm}) \times 60\text{cm} \\ &= 297\,000\text{cm}^3\end{aligned}$$

This needs linking back to capacity: $297\,000 \text{ cm}^3 = 297\,000\text{ml} = 297 \text{ litres}$

Topic 5 Surface Area and Volume of 3D Objects

Conversions

Although part of this has already been covered in the notes on Area and perimeter of 2D shapes it is worth looking at again. This time with the focus on 3D shapes.

Volume:

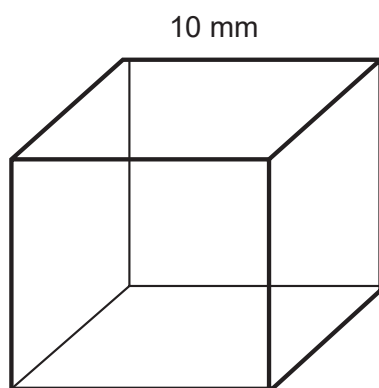

$$\begin{aligned}\text{Volume} &= l^3 = (10\text{mm})(10\text{mm})(10\text{mm}) \\ &= 1000\text{mm}^3\end{aligned}$$

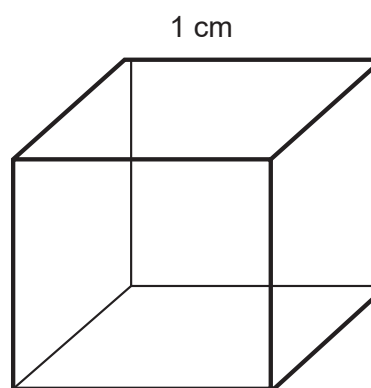

$$\begin{aligned}\text{Volume} &= l^3 = (1\text{cm})(1\text{cm}) \\ &= 1\text{ cm}^3\end{aligned}$$

As the cubes are the same size ($10\text{mm} = 1\text{cm}$), their volumes must also be the same: $1000\text{ mm}^3 = 1\text{ cm}^3$

Normally we would think of the conversion $1\text{cm} = 10\text{mm}$, but since we are dealing with volume we need to remember that

$$1\text{ cm}^3 = 10\text{mm} \times 10\text{mm} \times 10\text{mm} = 1\,000\text{ mm}^3$$

Here is a summary of the more common conversions required:

AREA		VOLUME	
$1\text{ cm}^2 = 100\text{mm}^2$	[10 x 10]	$1\text{ cm}^3 = 1\,000\text{mm}^3$	[10 x 10 x 10]
$1\text{m}^2 = 10\,000\text{cm}^2$	[100 x 100]	$1\text{ m}^3 = 1\,000\,000\text{ cm}^3$	[100 x 100 x 100]
$1\text{km}^2 = 1\,000\,000\text{m}^2$	[1000 x 1000]	$1\text{ km}^3 = 1\,000\,000\,000\text{m}^3$	[1000 x 1000 x 1000]

Topic 5 Surface Area and Volume of 3D Objects

RESOURCES

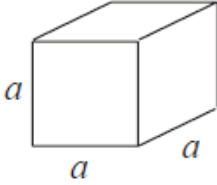
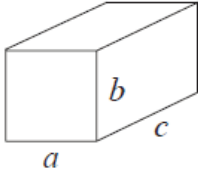

RESOURCE 1

Shape	Volume	Surface area
 <p>Cube</p>	$volume = side^3$	$SA = (side^2) \times 6$
 <p>Cuboid or rectangular prism</p>	$volume = length \times breadth \times height$	$SA = (2lb) + (2bh) + (2lh)$